

DH-PFA137-G

Water-proof Junction Box



Features

- Aesthetic design
- Material: aluminum
- Water-proof junction box

Technical Specifications

| | |
|-----------------------|----------------------------------|
| Model | DH-PFA137 |
| General | |
| Material | Aluminum |
| Dimension | Φ122.0mmx34.2mm (Φ4.80"x1.35") |
| Inch Thread | M20(G1/2") |
| Load Bearing | 1.0kg(2.2lb) |
| Weight | 0.24kg(0.53lb) |
| Color | White |
| Operating Temperature | -40°C~+60°C(-40°F~+140°F) |
| Humidity | <90% RH |
| Applicable Model | Please see "Accessory Selection" |

Order Information

| Type | Part Number | Description |
|--------------|-------------|--------------------------|
| Camera Mount | DH-PFA137-G | Water-proof junction box |
| | PFA137 | Water-proof junction box |

Dimensions (mm/inch)

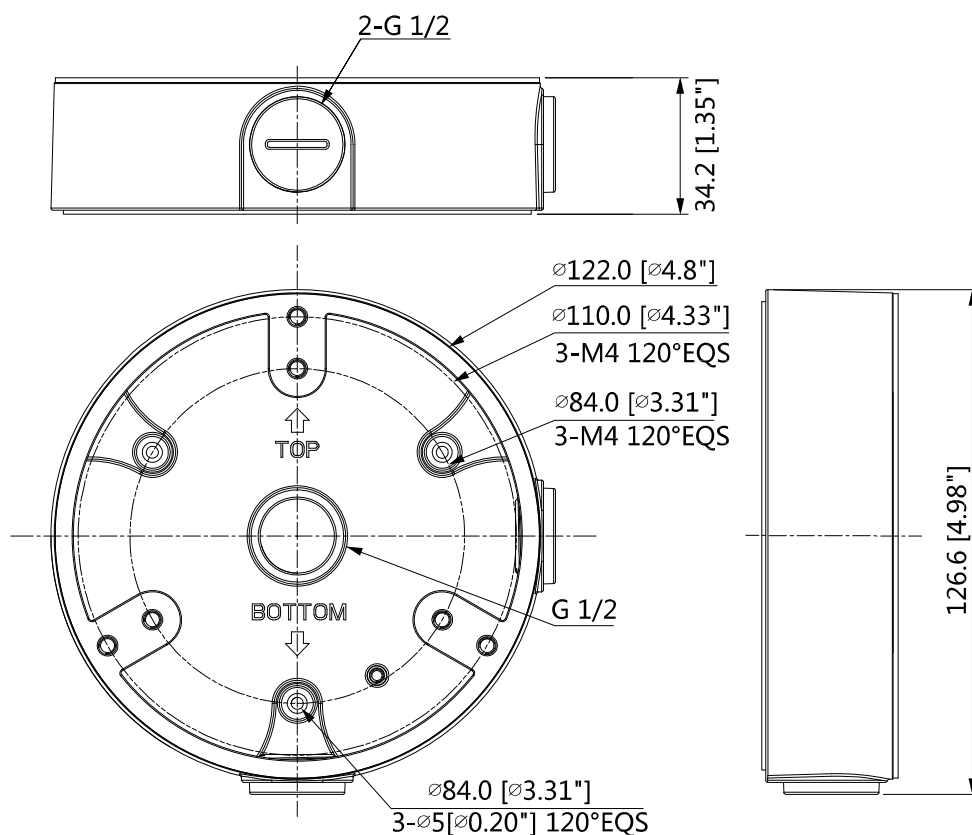

Application

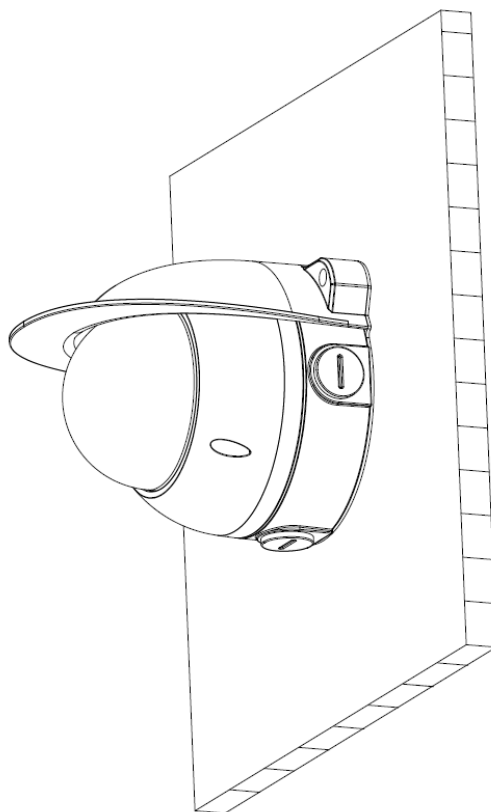

Package Information

- Water-proof junction box *1
- M4x12 screw *3
- ST4x25 screw *3
- Plastic anchor: 3
- Water joint *1
- Wrench *1